

# Modulating Actuator Motor

## DMA Series

**DUNGS**<sup>®</sup>  
Combustion Controls



### UL Recognized

- UL File # E142163
- UL 873
- CSA C22.2 No. 24-93

### CSA Certified

- CSA File # 1378915
- UL 429
- CSA C22.2 #139

### Compliant to the EU Low Voltage and EMC Directive

### US and Canadian Models

- DMA 6B120
- DMA 12B120
- DMA 30B120

### Commonwealth of Massachusetts Approved Product

- Approval code G1-1107-35
- Actuator Drive for Gas Butterfly valve.

### Codes and Standards:

This product is intended for installations covered by but not limited to NFPA 86, ANSI Z83.4/ CSA 3.7, ANSI Z83.18/ CSA 4.9, ANSI Z21.13, CSD-1, UL 795, or CSA B149.3.

### DUNGS is an ISO 9001 manufacturing facility.

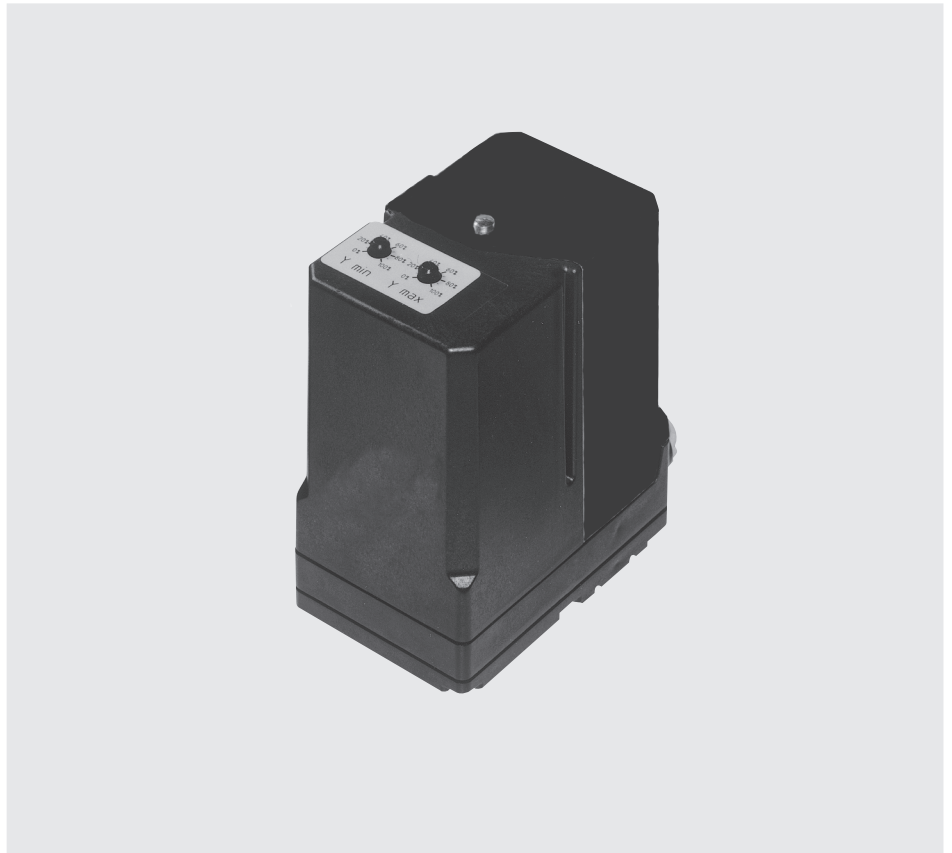

### Technical description

The DMA actuator drives from 0° to 90° via a 4 - 20 mA input signal. It can move in any direction and stop anywhere over the entire 90° stroke. The field adjustable stroke is factory set at 90° and the position is factory set at 0°.

The DMA is available in three different set speeds: 6s, 12s or 30s. The DMA has one independent, field adjustable auxiliary SPDT switch and two field adjustable limit switches.

During power interruption, the actuator will remain stationary. After power is restored, the position is determined by the controller input signal. However, if the 4 - 20 mA signal is interrupted and the DMA is still powered, the actuator will drive fully CW (towards 0°), which will

close the DMK butterfly control valve.

4-20 mA feedback can be used to drive a slave motor (3 actuators maximum in parallel).

Maximum stroke (Y max; span) is adjustable from 25° to 90°, and minimum stroke (Y min; zero) is adjustable from 0° to 75% of the set span (maximum stroke).

### Application

When mounted on the DMK butterfly control valve, the DMA is used to automatically modulate the amount of natural gas, butane, propane and/or air supplied to the burner.

## Specifications

Type	DMA 6B120	DMA 12B120	DMA 30B120
Operating time for 90° stroke	6s	12s	30 s
Resolution (max)	0.08mA resolution; minimum of 0.45° per step		
Electrical ratings	110 - 120 VAC 50-60 Hz		
Power rating	Holding: max. 2.0 VA Operation: max. 5.4 VA		
Enclosure rating	NEMA 1 (NEMA 4 option)		
Electrical connection	Screw terminals with 1/2" NPT conduit connection		
Operation time	100 % duty cycle		
Ambient temperature rating	+15 °F to +120 °F (-10 °C to 50 °C)		
Limit Switches (ST)	Two field adjustable switches: min and max: limit stroke of actuator.		
Auxiliary Switch (MV)	One SPDT, field adjustable switch. 10.5 A resistive, 10.5 A FLA, 9 A LRA @ 120 Vac		
Operating mode	Automatic		
Input Control	4 to 20 mA, 30mA max.		
Position Feedback/Output (for slave actuating or actual shaft position verification)	4 to 20 mA; max impedance for output is 500 Ohm.		
Holding Torque	6 s (12.4 in-lb)	12 s (24.8 in-lb)	30 s (26.5 in-lb)
Operating Torque	6 s (5.3 in-lb)	12 s (8.9 in-lb)	30 s (17.7 in-lb)
Mounting Position	Multipoised		
Weight	1.21 lbs (0.5 kg)		
Direction of Rotation	Counterclockwise		

## Wiring diagram

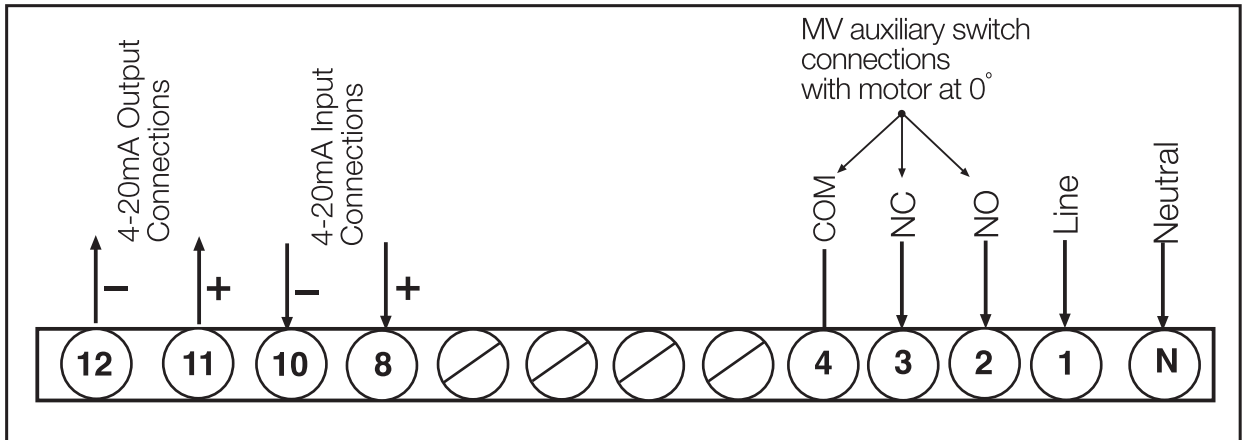

## Actuator operation (view from bottom of DMA)

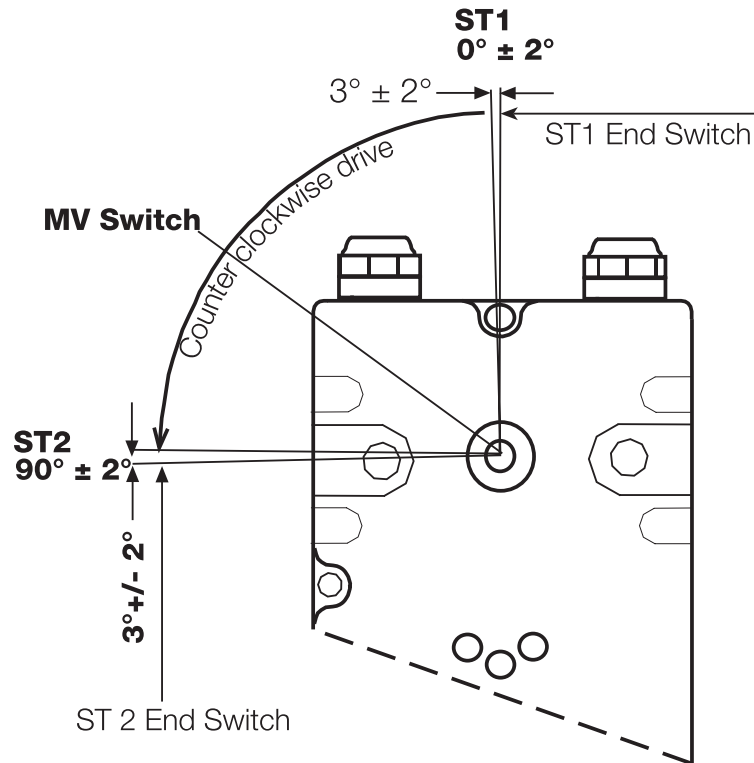

**Actuator Motor  
DMA**



**Dimensions inch (mm)**

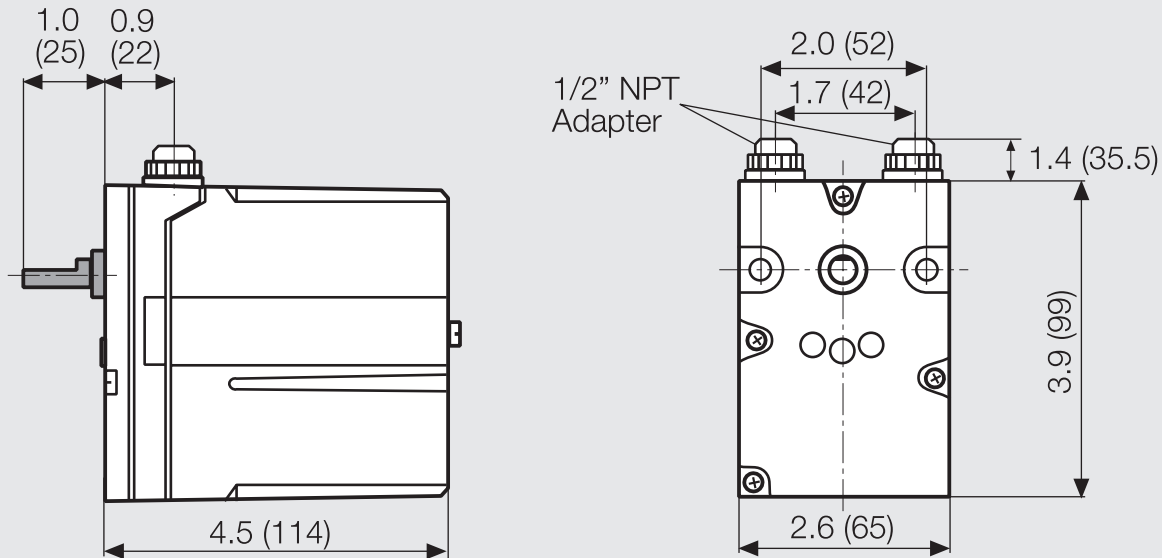

Type	Order No.
DMA 6B120*	46050-1
DMA 12B120	46050-2
DMA 30B120	46050-3
NEMA 4 metal enclosure option	240-456

\* Special Order. Minimum quantities may apply.

**Karl Dungs Inc.**  
**524 Apollo Drive, Suite 10**  
**Lino Lakes, MN 55014, U.S.A.**  
**Phone 651 792-8912**  
**Fax 651 792-8919**  
**e-mail [info@karldungsusa.com](mailto:info@karldungsusa.com)**  
**Internet <http://www.dungs.com/usa/>**

**Karl Dungs GmbH & Co. KG**  
**P.O. Box 12 29**  
**D-73602 Schorndorf, Germany**  
**Phone +49 (0)7181-804-0**  
**Fax +49 (0)7181-804-166**  
**e-mail [info@dungs.com](mailto:info@dungs.com)**  
**Internet <http://www.dungs.com>**